

SOPRASOLAR FIX EVO PVC PEDESTAL

The **Soprasolar Fix EVO PVC pedestal** is a component of the **SOPRASOLAR FIX EVO Tilt PVC** system, which is a rigid photovoltaic system that is integrated into PVC roof waterproofing.

Description

The **SOPRASOLAR FIX EVO PVC PEDESTAL** is made up of a height-adjustable base in glass fibre reinforced polyamide that is mechanically joined to a **SOPRASOLAR PVC BASE PANEL**.

It makes it possible to join PV modules to the waterproofing without piercing the waterproofing.

Components

	SOPRASOLAR PVC BASE PANEL
Reinforcement	Polyester matrix
Binder	Plasticised PVC
Min. thickness	2 mm
Dimensions	370 ^{±1} mm x 250 ^{±1} mm
Weight (guidance)	0.2 kg approx.

	ADJUSTABLE PEDESTAL
Material	PA 6 GF30
Height adjustable	from 120 mm to 160 mm approximately
Fastening to the base panel	4 Isolagri washers 4 M6 stainless steel bolts 4 stainless steel washers 4 stainless steel split washers
Min. support surface	578 cm ²

Specifications

SOPRASOLAR – 202, Quai de Clichy – F- 92110 CLICHY
 Tel: +33 (0)1 46 88 01 80 - Fax: +33 (0)1 46 88 01 89
www.soprasolar.com • Email: contact@soprasolar.com

Soprema AG • Härdlistrasse 1-2 • CH-8957 SPREITENBACH • www.soprema.ch • info@soprema.ch • Tel. +41(56) 418 59 30
 Soprema NV • Bouwelven 5 – B-2280 GROBBENDONK • www.soprema.be • info@soprema.be • Tel. +32 14 23 07 07

SOPREMA
GROUP

	SOPRASOLAR FIX EVO PVC PEDESTAL
Overall dimensions	250 mm x 370 mm x 120 -160 mm
Mass	0.96 kg
Vertical tensile strength	1700 N
Resistance to outdoor conditions	All environments other than mixed, aggressive or severe environments

		SOPRASOLAR PVC BASE PANEL
Maximum tensile force at break (EN 12311-2):	Manufacturer's limit value	≥1100 N/5 cm
Elongation at break (EN 12311-2):	Manufacturer's limit value	15 %
Pliability at low temperature (EN 495-5):	Manufacturer's limit value	-25 °C
Dimensional stability after 6 hours at 80 °C (free shrinkage) (EN 1107-2)	Manufacturer's limit value	< 0.5 %
Static puncture resistance (EN 12730: 2001) method A	Manufacturer's limit value	≥20 kg
Nail tear strength (EN 12310-1):	Manufacturer's limit value	≥500 N
Durability test – temperature ageing: 24 weeks at 70 °C: - pliability (UEATC guide 4.4.1.1 EN 495-5) - Tensile strength - elongation (UEATC guide 4.4.1.1 EN 12311-2)	Manufacturer's limit value	Δ ≤10 °C +/- 20 %

Manufacturer's limit value: Manufacturer's limit value: minimum value liable to be provided as part of the quality system

Use & installation

SOPRASOLAR FIX EVO PVC PEDESTALS must be stored on a flat surface protected from bad weather and significant temperature variations.

SOPRASOLAR FIX EVO PVC PEDESTALS must be installed according to the **SOPRASOLAR FIX EVO TILT PVC/TPO** installation instructions supplied by **Soprasolar**.

Specific information

Health, safety and the environment:

SOPRASOLAR FIX EVO PVC PEDESTALS do not contain any hazardous components. They generally meets all health, safety and environment requirements.

Illustration

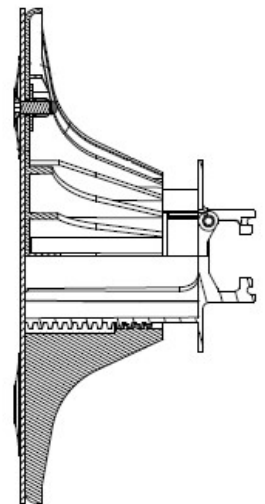
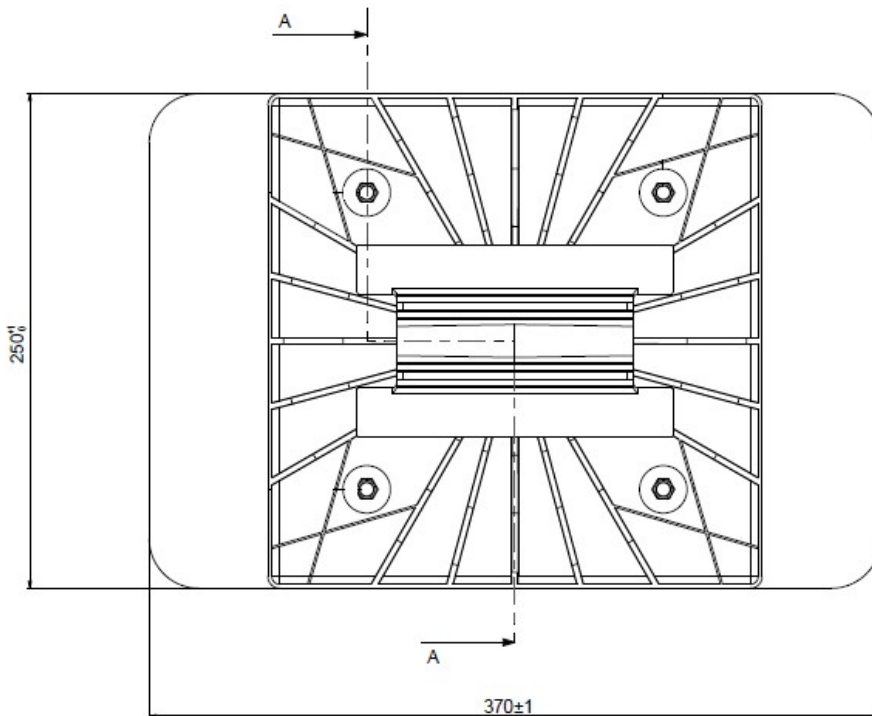
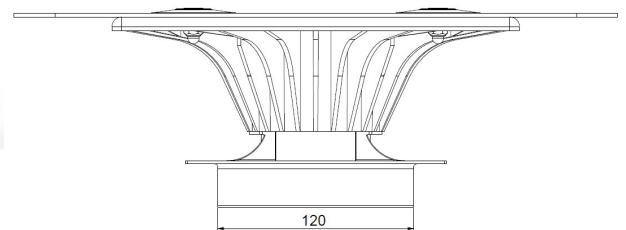
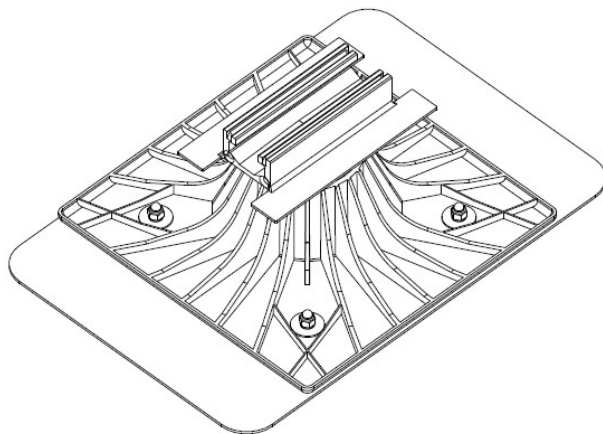

COUPE A-A

